

# ROBOCUT $\alpha$ -C400iB Mechanical specifications

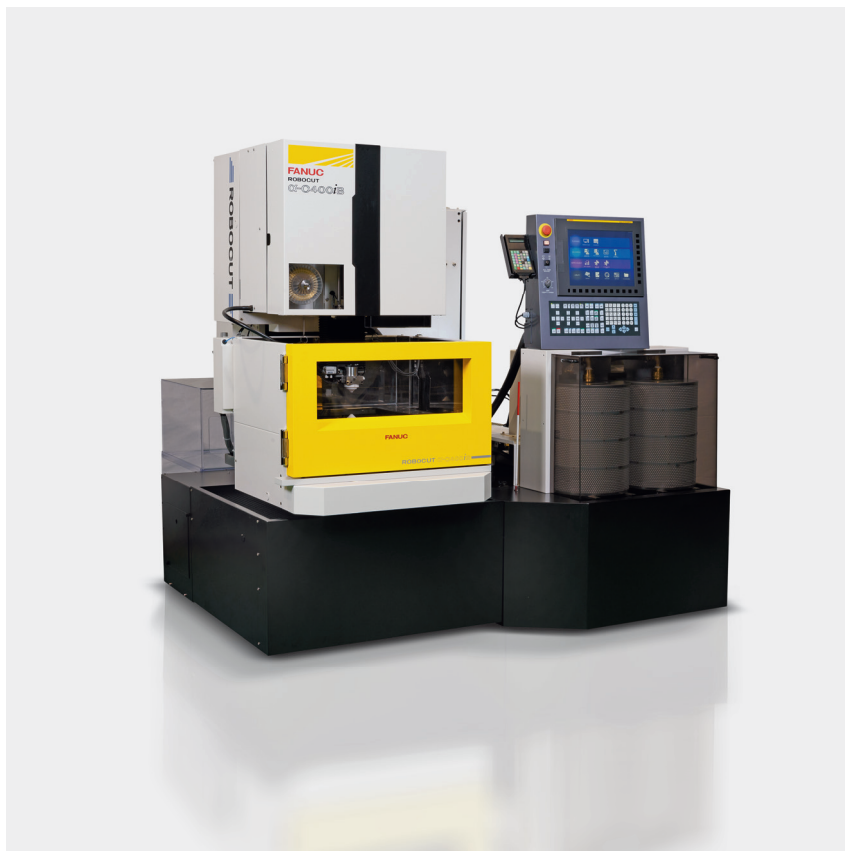



Standard	
Maximum workpiece dimensions [mm]	730 x 630 x 250
Maximum workpiece weight [kg]	500
XY axis table travel [mm]	400 x 300
Z axis travel [mm]	255
UV axis travel [mm]	120 x 120
Maximum taper angle [°/mm]	±30°/80
Minimum step increment of the drives [mm]	0,0001
Wire diameter [mm]	Ø 0.10 ~ Ø 0.30
Maximum wire weight [kg]	16
Footprint (W/D) [mm]	1990 x 2200
Machine weight (approx.) [kg]	1800
Controller	FANUC 31i-WB
Part program storage size [MB]	4
Acoustic noise level	
LPA [dB]	64
LPCpeak [dB]	81
Optional	
Thin wire	
Wire diameter [mm]	Ø 0.05 ~ Ø 0.07
Automatic front door	
Maximum workpiece dimensions with automatic door, Z axis travel [mm]	730 x 585 x 250
45° die guide	
Maximum taper angle [°/mm]	±45°/40
30 kg wire feed unit	
Maximum wire weight [kg]	30

## Installing Conditions

<b>Power supply</b>	AC200V±10% 3-phase 50/60Hz ±1Hz, AC220V±10% 3-phase 60Hz ±1Hz, Connection cable terminal size: 8-5, Power consumption: 13kVA
<b>Air supply</b>	Air pressure: 0.5 - 0.7 MPa, Flow rate: 100 - 110 L / min or more: 120L / min or more (with a thin wire option) *Regulator-side coupler mounting screw: Rc1/4
<b>Shield room</b>	If discharge noise can interfere with surrounding radio, television and other sets, a shield room needs to be created
<b>Environment</b>	Ambient temperature: 15-30°C, *Recommend 20±1°C for high precision machining. Install under the oil mist free and dust free environment. Humidity: 75% RH or less
<b>Grounding</b>	The unit must be grounded to avoid damage resulting from electro-magnetic interference or electrical leakage. The grounding itself should be of type C (grounding resistance of 100 max.) as specified in the electrical installation standards and should be carried out independently of the grounding of any other piece of machinery (one piece grounding).

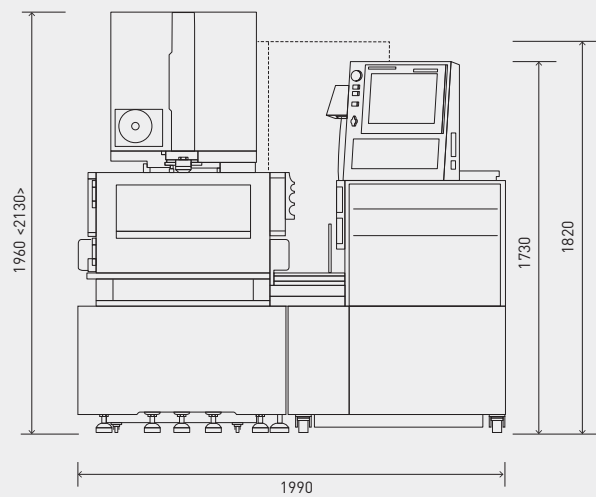
# ROBOCUT $\alpha$ -C400iB Outer Dimensions | Floor Plan



 Power input position

 Compressed air input position

\* The values in parentheses < > are when the safety cover is open.

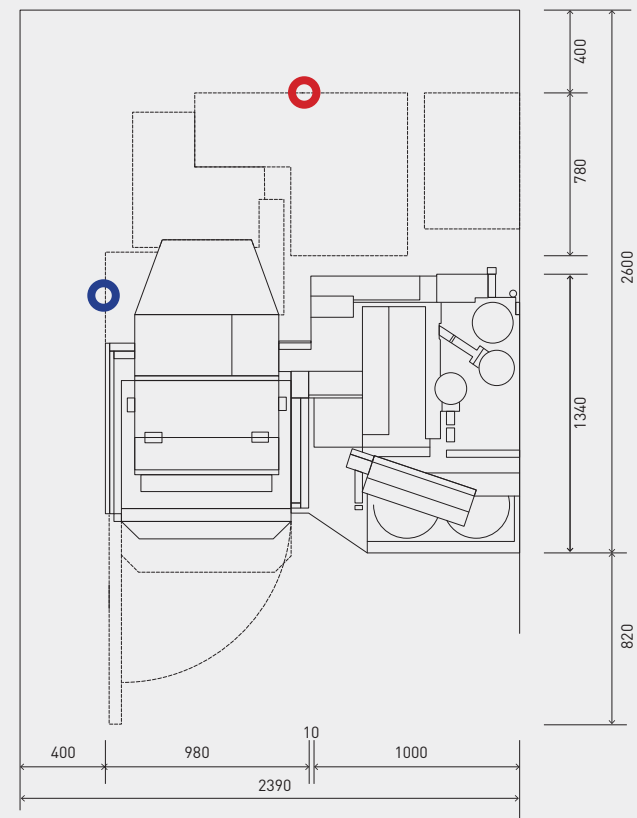

\*) The above floor plan is that of a standard type machine.

Contact FANUC if you wish to order options such as 30 kg wire feed unit and thin wire option.